



Manufacturer & Supplier Of
OVER HEAD CRANES | JIB CRANES | WIRE ROPE CRANES



**ALL TYPES OF
MATERIAL
HANDLING
EQUIPMENTS**

www.starlinecrane.com | www.doublegirdercrane.com

ABOUT US



ALL TYPES OF MATERIAL HANDLING SOLUTION

Established as a Sole Proprietorship firm in the year 2019, we "STARLINE CRANES PVT. LTD." are a leading Manufacturer of a wide range of EOT Cranes, Electric Hoist, Goliath Crane, etc. Situated in Ahmedabad (Gujarat, India), we have constructed a wide and well functional infrastructural unit that plays an important role in the growth of our company. We offer these products at reasonable rates and deliver these within the promised time frame.

Under the headship of "Mr. Krunalkumar Hitendrabhai Patel" (Director), we have gained a huge clientele across the nation.

OUR COMPANY



COMPANY PROFILE

Starline Crane Pvt. Ltd., is one of the Top Leading Manufactures of Material handling equipments.



OUR TEAM

Our team members are the most worthy asset to the company. their distinct social and educational background in



QUALITY POLICY

Load Testing: Starline Industries provide a full range of load testing services for your lifting equipments.



CUSTOMER FOCUS

Achieving complete customer satisfaction is our prime focus. Our marketing and support teams meet with customers



DOUBLE GIRDER EOT CRANE

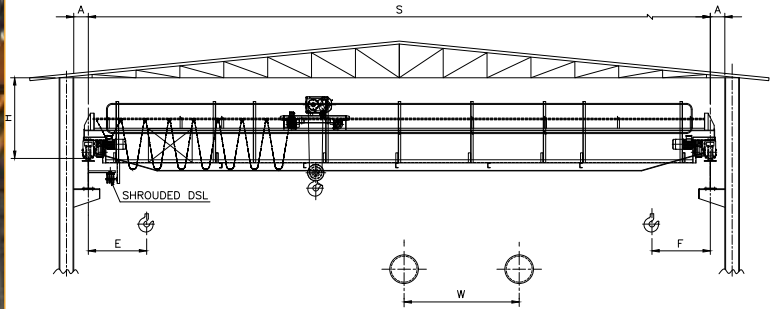

SWL (M.T.)	Span (Mtrs.) 'S'	Head Room (mm) 'C'	End Clearance (mm) 'A'	Hook Approaches		Wheel Base (mm) 'w'	Total Weight in Ton (approx.)	Wheel Load (Approx.) (MT)
				(mm) 'E'	(mm) 'F'			
5	10	1700	260	950	850	2800	7	
	15	1700	260	950	850	3000	10	
	20	1800	260	950	850	3300	14	6
7.5	10	1800	260	1000	900	2800	8	5.7
	15	1800	260	1000	900	3000	13	7
	20	1900	260	1000	900	3300	17	8
10	10	1900	260	1100	1000	2800	9	7.2
	15	1900	260	1100	1000	3000	14	8.5
	20	2100	280	1100	1000	3300	18	9.5
15	15	2400	280	1100	1000	3000	17	12
	20	2600	280	1100	1000	3800	23	13
20	15	2500	320	1200	1000	3800	21	15
	20	2700	320	1200	1000	4000	28	17
25	15	2700	320	1250	1100	3800	20	17.5
	20	3000	320	1250	1100	4000	30	20
30	15	2800	320	1300	1100	4000	24	21
	20	3000	320	1300	1100	4200	32	22
40	15	3200	330	1400	1200	4600	30	27.5
	20	3500	330	1400	1200	4800	38	29.5
50	15	4000	360	1500	1250	4800	42	37
	20	4500	360	1500	1250	5000	48	39
60	15	4200	425	1700	1350	5800	62	50
	20	4700	425	1700	1350	6000	72	52

SINGLE GIRDER EOT CRANE

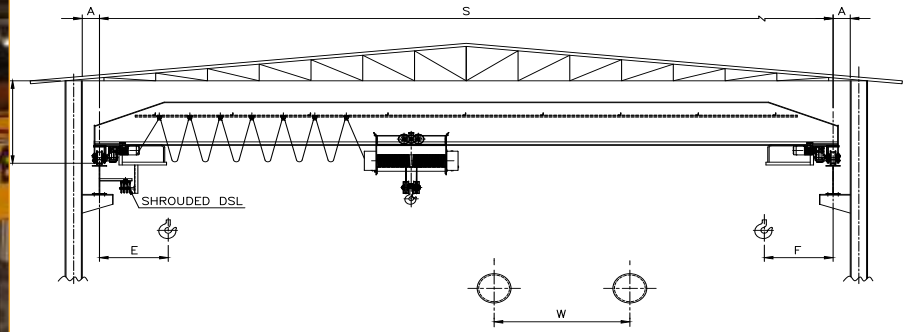

We are engaged in manufacturing and supplying premium quality range of Single Girder EOT Crane which are used for moving loads in different such as up, down, right and left easily. These machines are widely acclaimed for their qualities like high performance and optimum quality. The offered machines are manufactured using high quality basic raw materials that is procured from our trustworthy vendors of the industries. Further, this industrial single girder crane is available in various standard and tailored specifications which are offered at the most reasonable prices.

SWL (M.T.)	Span (Mtr.) 'S'	Head Room (mm) 'C'	Wheel Base (mm)	Hook Approach (mm) E/F	End Clearance (mm) A	Wheel Load Per Wheel (Aprox.)
2	5	850	2000	700	270	1.6
	10	950	2000	700	270	1.7
	15	1050	2800	700	270	1.9
	20	1200	2800	700	270	2.3
3	5	850	1900	800	275	2.07
	10	950	2000	800	275	2.2
	15	1100	2800	800	275	2.6
	20	1300	2800	800	275	3.2
5	10	1000	2000	900	275	3.5
	15	1250	2400	900	275	4
	20	1350	2800	900	275	4.4
7.5	10	1100	2000	950	300	5.02
	15	1300	2400	950	300	5.5
	20	1500	2800	950	300	6.02
10	10	1200	2200	1000	300	6.5
	15	1400	2400	1000	300	7.1
	20	1550	2800	1000	300	7.6

ELECTRICAL WIRE ROPE HOIST

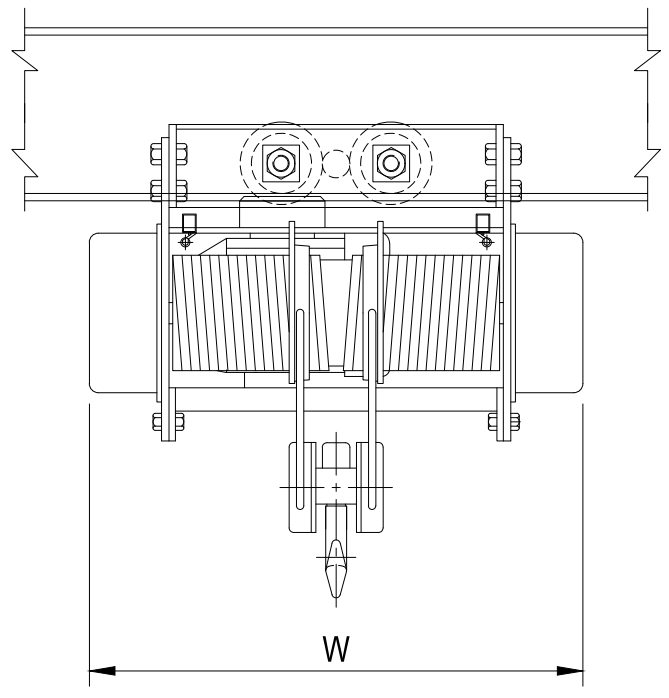
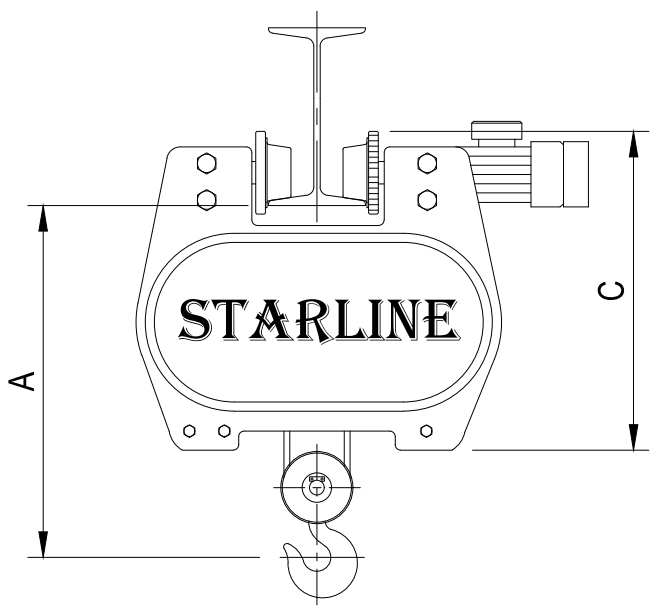

Starline Cranes Pvt. Ltd. wire rope hoists are designed in modular constructions which greatly simplifies repairs & cuts downtime.

The Hoists are compact, rugged & elegant in appearance to accommodate specific requirements, our hoists cab also be built with micro speed arrangements (10% normal hoisting speed), flexible trolleys to negotiate small radius, high speeds & high lifts, hoist suitable for steel mill duty foundries & chemicals plants.

SWL (kg.)	STANDARD LIFT MTR	SPEED MPM		MOTOR HP		NO OF FALLS		DIMENSIONS			Weight (Kg)
		HOIST	CT	HOIST	CT			A	C	w	
1000	6	4	15	1.5	0.25	2		600	585	740	160
2000	6	4	15	3	0.5	2	4	820	660	890	220
3000	6	4	15	5	0.5	4		850	690	920	270
5000	6	4	15	7.5	0.75	4		950	762	1050	380
7500	6	4	15	10	1	4		950	790	1050	500
10000	6	4	15	12.5	1.5	4		1200	970	1250	900
12500	6	3	10	15	1.5	4		1600	1300	1350	1300
15000	6	3	10	17.5	2	4		1800	1200	1500	1500

ELECTRICAL CHAIN HOIST

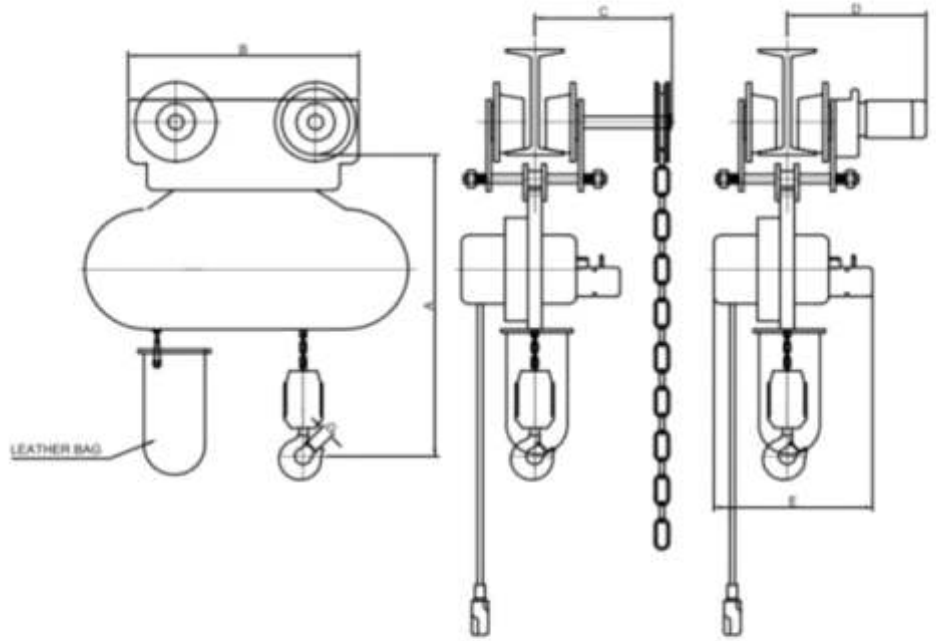

We are quality oriented manufacturer & exporter of the best range of Chain Hoists. These are widely used with various types of cranes, I-beam etc., in warehouse, mining and other industries. Our offered Chain Hoist are admired a lot in the industry for their stable performance, safe usage, long service life and flexible operations. Moreover, Our entire range is fabricated in accordance need of the industrial clients.

Capacity		1 Ton	2 Ton	3 Ton	5 Ton	7.5 Ton	10 Ton
Height (mtr)		3	3	3	3	3	3
Speed	Hoist	4.13	2.3	2.3	2.3	1.8	1.4
	CT	12	12	12	12	10	10
Motor	Hoist	1	1	2	3	5	5
	CT	0.25	0.5	0.5	1	1	1.5
No. Of Fall		1	2	2	2	3	4
A		450	500	600	750	900	1000
B		280	360	360	420	420	460
C		300	350	370	450	450	500
D		300	350	370	450	450	500
E		550	550	650	650	700	730

CRAB FOR EOT CRANE

We manufacture various ranges of Crabs. These are designed as per industry standards and are offered in various specifications to meet the varied application demands.

We offer these hoists at market leading prices within the stipulated time period.

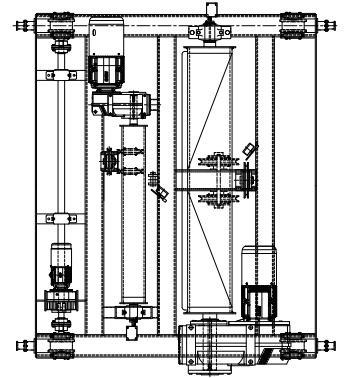
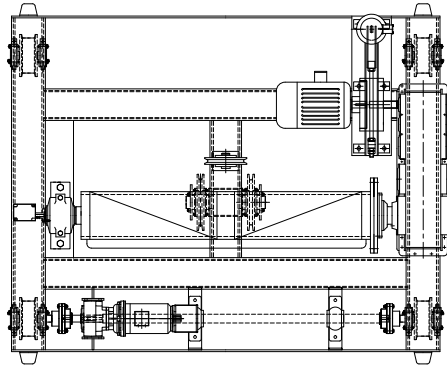

Industrial Crabs can be supplied as standard units or can be custom made. They offer maximum advantages when working in open. These Hoist Crabs can have single or twin hoist units as required. The driving arrangement can either be with hand-gear or motor-driven type. Micro speed arrangement in hoisting can be provided if required.

TECHNICAL SPECIFICATION OF M.E. CRAB HOIST

Power Source	Electric
Usage / Application	Industrial
Capacity	UP TO 100 TON
Trolley Option	With Trolley, Without Trolley
Wire length (Mtrs.)	6-100 Mtr
Material	Mild Steel

FLAME PROOF ELECTRICAL WIRE ROPE HOIST

Available with electrical components housed in flame proof enclosures conforming to IS-2148, and mechanical components designed with spark proofing features.

- Capacity** : 1000 Kgs to 15000 Kgs.
- Lift** : 6 mtrs. to 60 mtrs.
- Hoisting Speeds** : 3-10 mpm.
- CT Speed** : 10-20 mpm
- Travel** : Straight Path
Curved Path
- Type** : Power Travel
Hand Travel
Fix Suspension

Suitable For:

- Zone 1, Gas Group IIA, IIB
- Zone 2, Gas Group IIA, IIB, IIC



OUR CUSTOMER



PARAS DEFENCE & SPACE
TECHNOLOGIES LIMITED



DP WORLD



Jamna Auto Industries Ltd.



भारत डायनामिक्स लिमिटेड
BHARAT DYNAMICS LIMITED





📍 1, Sun Industrial Park, Nr. tech Flow Enterprise,
Vill-kubudthal, Indore Highway, Ahmedabad,
Gujarat - 382 430, India.

☎ +91 75678 77277

✉ starlinecranes@gmail.com

🌐 www.starlinecrane.com | www.doublegirdercrane.com

Follow us on:

